

Detect Hotspots In Your Cabinet

Monitor temperature differentials in your cabinet

Thermal maps consist of a string of 6x temperature sensors and an optional 2x humidity sensors. Pre wired to be easily installed in your cabinet, they are placed at the top, middle and bottom - front and rear of the cabinet. This configuration of sensors gives you monitoring of the air intake and exhaust temperatures of your cabinet, and the temperature differential from the front to the rear.

Thermal Map sensors are compatible with all sensorProbe+ base units, and are available in temperature only (6x temp), or dual temperature and humidity (6x temp, 2x hum). Sensors are provided with magnetic strips for attachment to your cabinet, or can be mounted using double sided VHB tape provided.

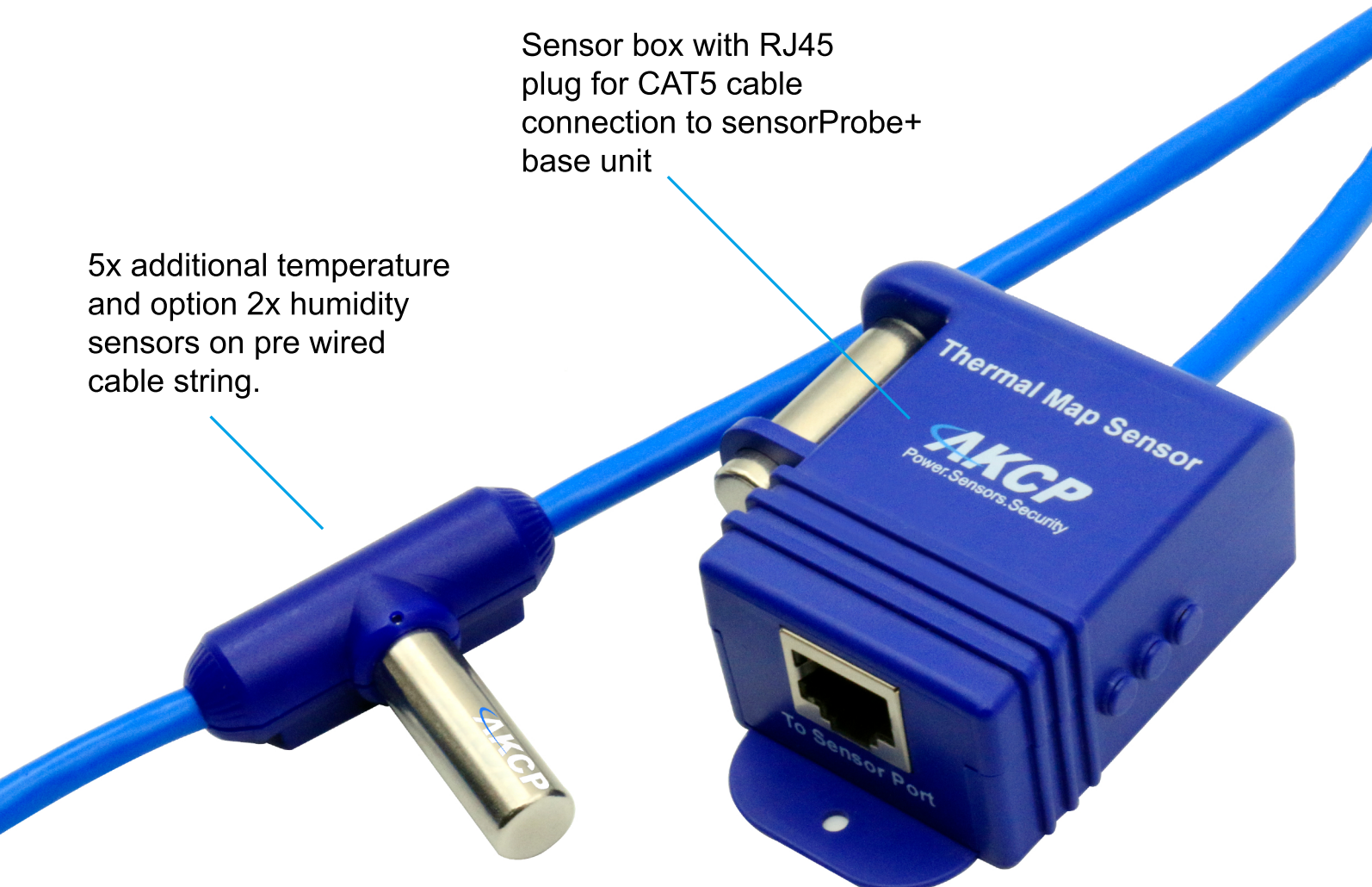

Sensor box with RJ45 plug for CAT5 cable connection to sensorProbe+ base unit

5x additional temperature and option 2x humidity sensors on pre wired cable string.

Rack Maps

Displaying temperature differential front to rear

sensorProbe+ and AKCP Pro Server display cabinet thermal maps in a graphical “Rack Map” view. This shows the status and value of each sensor and its position on the cabinet, as well as animated arrows denoting the front to rear temperature differential and its status.

Rack map views can also display the status of an attached RFID Swing Handle Cabinet Lock (SHL), and Sensor Status Light (SSL).

The measurement of the front to rear temperature differential is used to alert the following potential situations :-

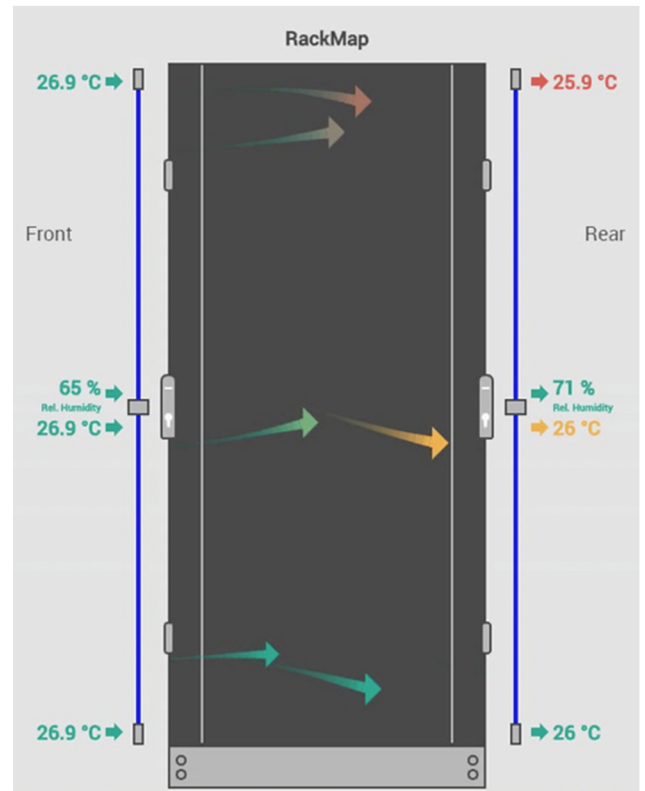

Obstructions within the cabinet

Cabling or other obstructions can impede the flow of air causing high temperature differentials between the inlet and outlet temperatures.

Server and cooling fan failures

As fans age, or fail, the airflow over the IT equipment will lessen. This leads to higher temperature differentials between front and rear.

Insufficient pressure differential to pull air through the cabinet

When there is insufficient pressure differential between the front and rear of the cabinet, airflow will be less. The less cold air flowing through the cabinet, the higher the temperature differential front to rear will become.

Power Usage Efficiency (PUE)

When the data is combined with the power consumption from the in-line power meter you can safely make adjustments in the data center cooling systems, without compromising your equipment, while instantly seeing the changes in your PUE numbers.

Power and Temperature on a single sensor port

Thermal maps can be connected to the in-line power meter to make a combined power meter and thermal map sensor that uses a single sensor port on the sensorProbeX+.

Application Diagram

Thermal Maps are easy to install, come pre wired and ready to mount. With magnetic or ultra high bond adhesive tape to hold them in position on your cabinet. Mount each sensor on the front and rear doors of your perforated cabinet so they are exposed directly to the airflow in and out of the rack.

Thermal map sensors connect to AKCP sensorProbe+ base units, such as the SP2+, SPX+ and SEC+. Extendable up to a maximum of 18 meters cable length, you can monitor multiple cabinets from a single IP address. Below example illustrates an SPX+ with 12 sensor ports, this is the maximum number of thermal maps that can be connected to a single SPX+.

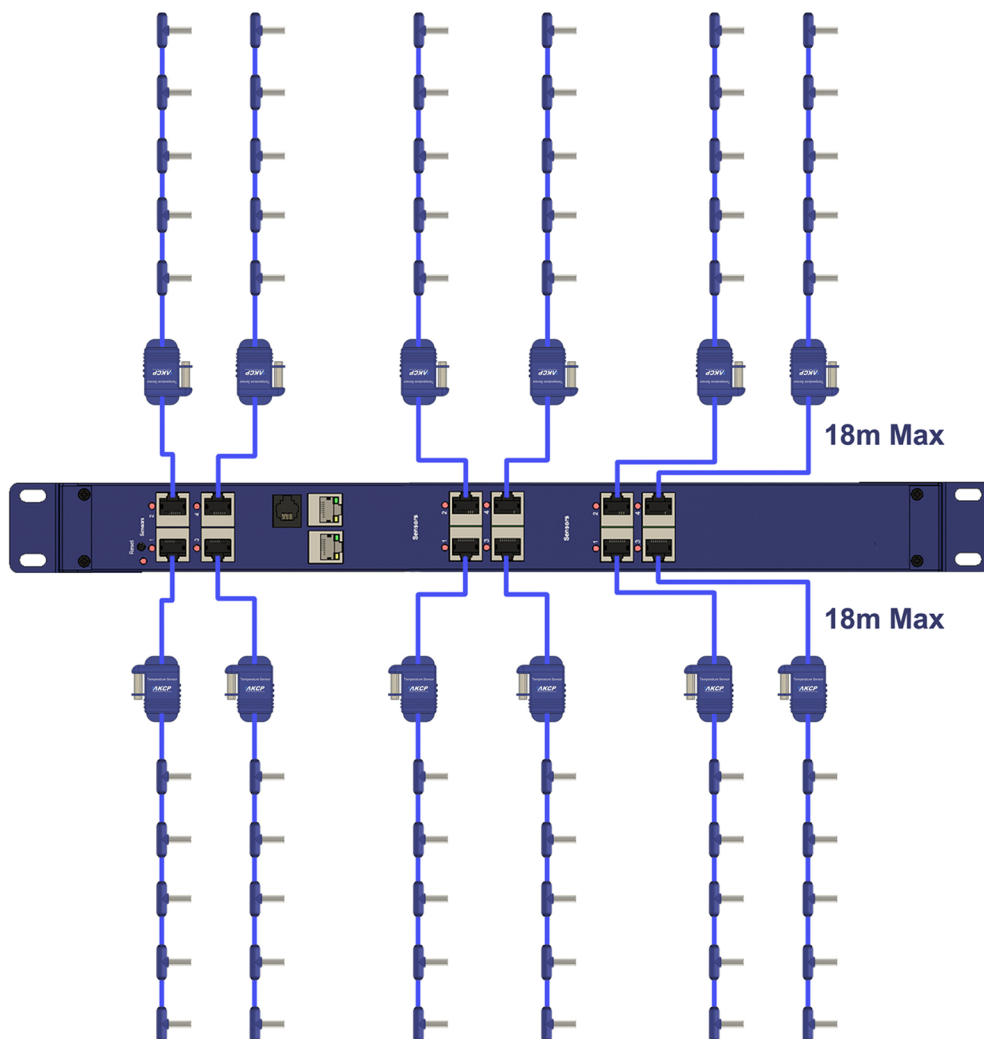

Maximum of 12 Thermal Maps connected to an SPX+



Thermal Map installed on cabinet

smartRack System

Use Thermal Map Sensors as part of an integrated smartRack solution. Combine Thermal Maps with an LCD display, RFID access controls wing handle cabinet locks, siren and strobe alarms and in-line power meters. make your cabinet part of the IoT world with our smartRack system. Monitor all your cabinets from a single user interface using AKCP Pro Server. Virtual sensors monitor third party devices such as your UPS and backup power systems. Integraed ONVIF IP cameras to playback video synchronized with sensor events.

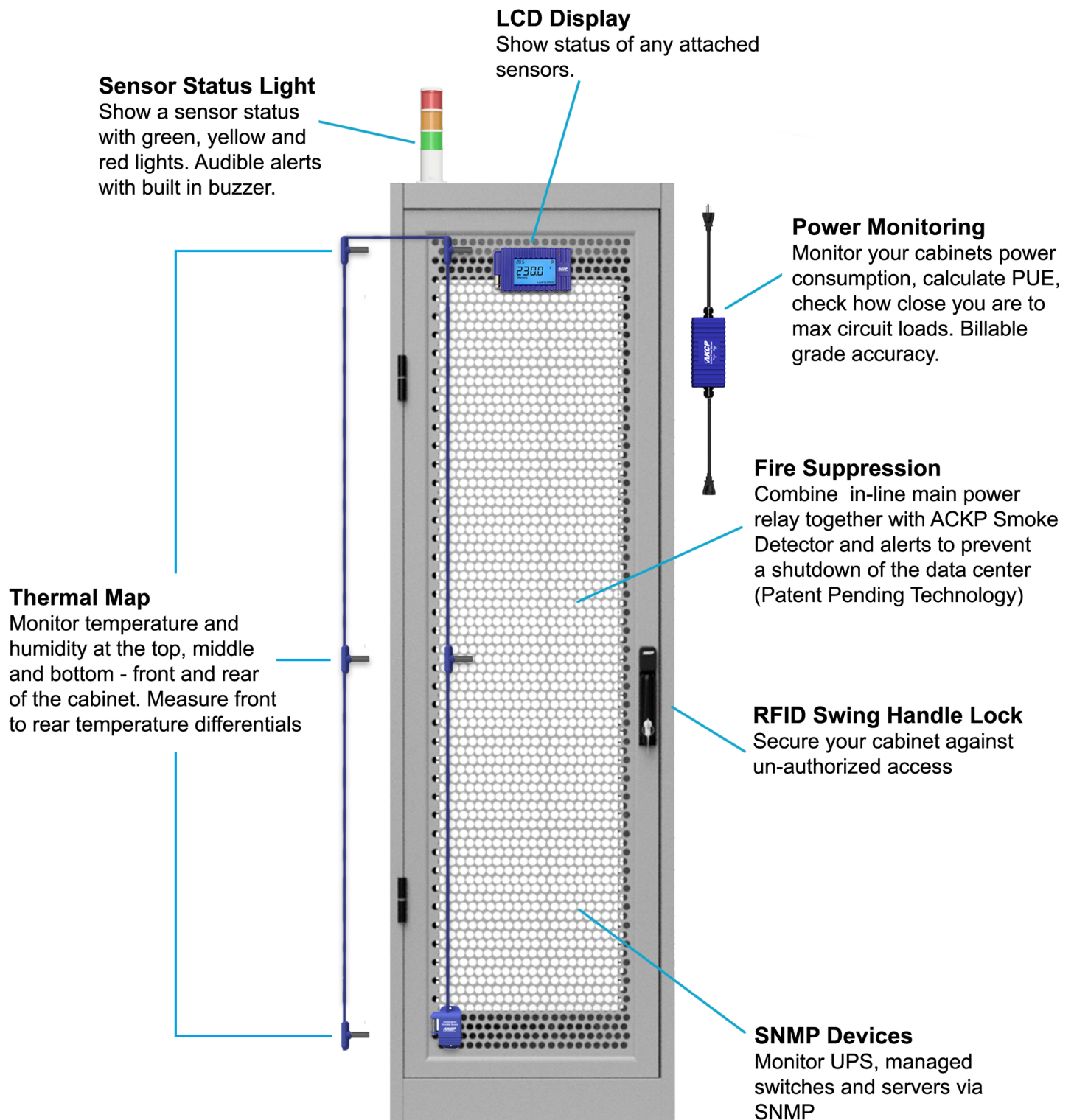

Technical Drawing

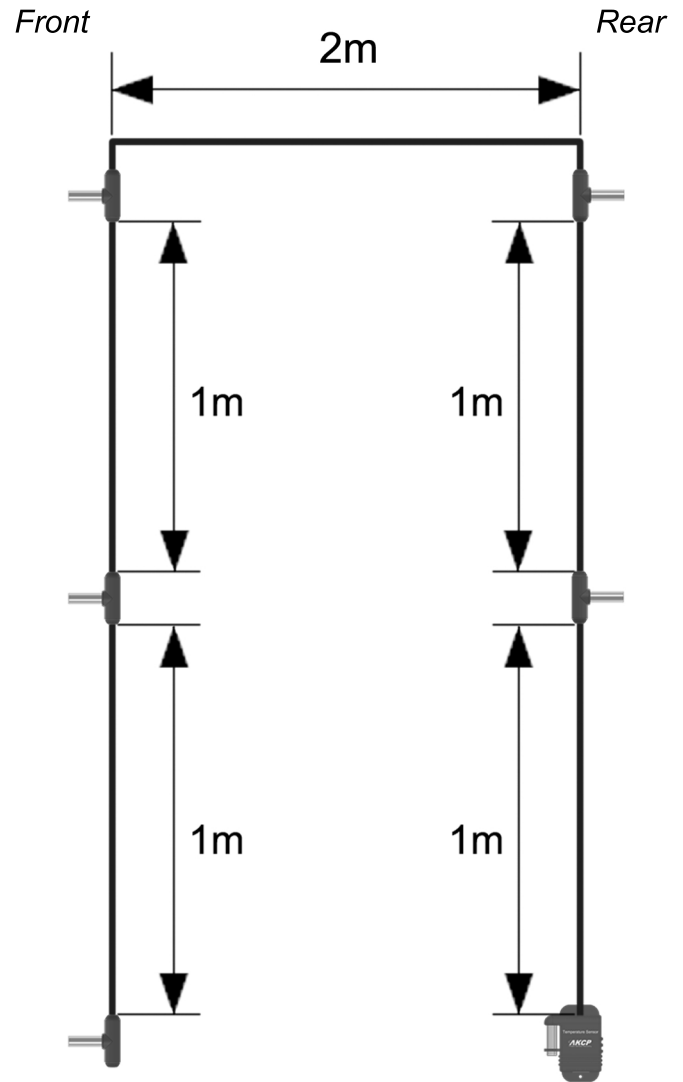
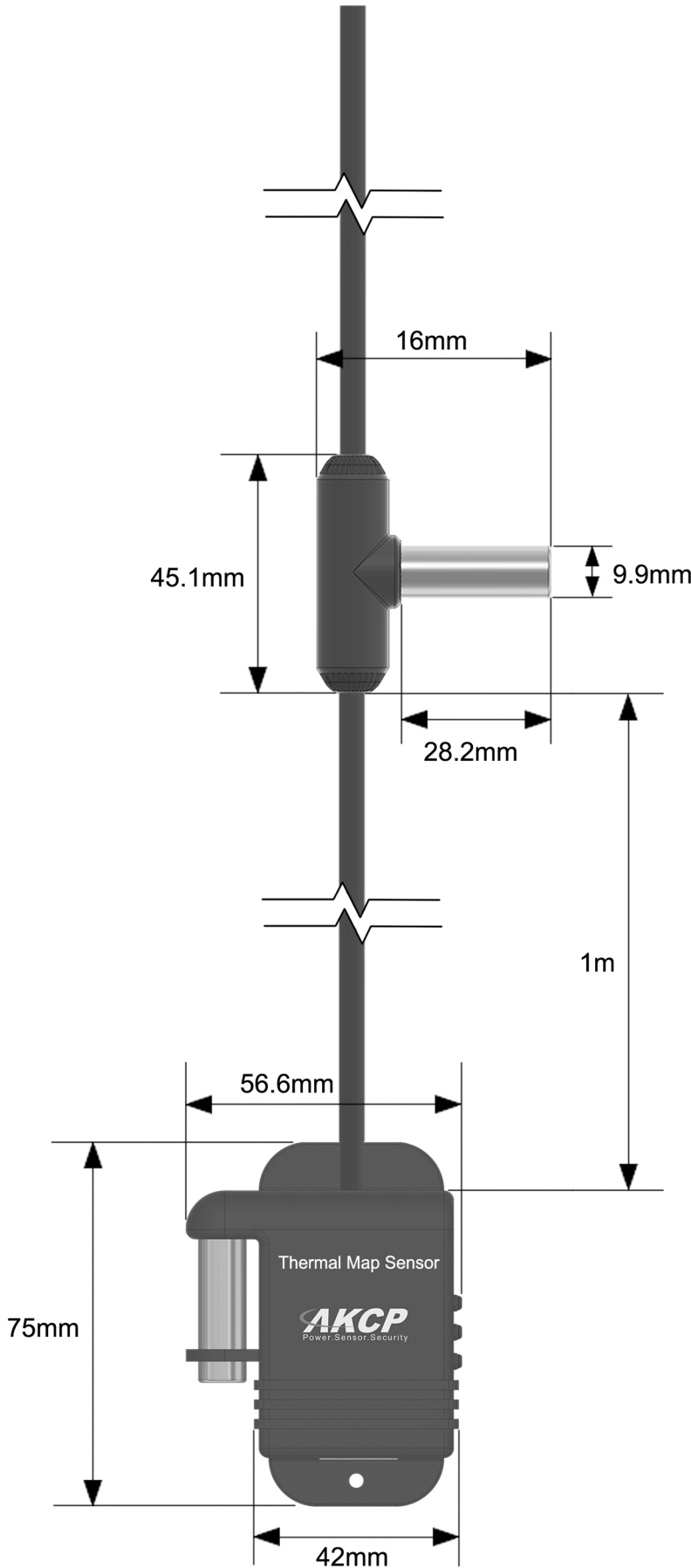

Thermal Map cabinet layout